



## The Center for Research Libraries

10/20/2005

### Archive Profile

# KB

**Koninklijke Bibliotheek – National Library of the Netherlands**

Compiled by Robin Dale, with contributions from the KB.

### **Organization**

#### **Governance**

The KB was founded in 1798 and since 1993 has been an autonomous administrative body financed by the Ministry of Education, Culture, and Science (OCW). The governing body of the KB is the Board of Governors, which consists of four members appointed by the Minister of Education, Culture, and Science. The Board of Governors has authority over the KB's regulation, management, and budget.

Within the framework of the policy laid down by the Board of Governors, the management of the KB is in the hands of the Director-General, Dr. Wim van Drimmelen. The Director-General, the Director of Collections & Services, and the Director of e-Strategy & Property Management constitute the directorate. The Director-General is accountable to the Board of Governors. In 2004, the structure of the directorate changed to its current configuration. Dr. Martin Bossenbroek was appointed to the position of Director of Collections & Services. Johan F. Steenbakkers, Director of Information Technology and Facility Management, became Director of e-Strategy and Property Management.

The Research and Development Division includes the Department for Digital Preservation which oversees all research into digital preservation issues. The e-Deposit System (or e-Depot as it is called) actually falls under the Acquisitions & Processing Division. For the purposes of the audit, leadership for the subject audit is being headed by Hans Jansen, acting Director e-Strategy, and operational support is being provided by Dr. Erik Oltmans, the former manager of the e-Depot and current Head of the Acquisitions & Processing Division.

#### **Funding**

The KB receives an annual grant from the Ministry of OCW, amounting to €31.6m in 2004. The grant is a lump sum, of which a part is earmarked, especially the amounts for rent and maintenance of the KB-building and for building up the collections. The other amounts are for personnel and material costs. The KB also has some self-earned income (library passes, document supply and

interest), which amounts to less than 10% of the annual budget. The KB may apply for additional funds to support special projects or investments in the infrastructure.

As for the e-Depot the KB has re-allocated funding within its own budget. In addition, since 2003 the KB receives an earmarked grant (€ 1.1m per year) from the Ministry for system maintenance and (part of) the staff handling the operations of the e-Depot. The maintenance is outsourced to IBM. The associated research and development budget (allotted to digital preservation through the R&D Division) was an additional €200,000 for staff. In 2004 an amount of €1m was added to the annual grant for permanent preservation (paper and digital preservation), including another €0.2m for R&D long-term preservation. In 2005 this earmarked grant went up to €2m, including €0.9m for R&D long-term preservation. The funds for research into digital preservation are expected to increase further in 2006 and 2007, subject to approval by the cabinet.

## **Policy and Agreements with Publishers**

Current international journals have no longer a fatherland that can be identified easily. Because of the involvement of two international publishers of Dutch origin (Elsevier and Kluwer), the e-Depot has had an international dimension right from the start. The early and successful implementation of the system and the commitment of Elsevier and Kluwer, based on trust and commercial interest, put the KB in a natural position to assume an international role. KB's policy is based on the view and experience that permanent archiving presupposes permanent commitment and takes substantial resources, both organizational and technical ones. Sustained R&D efforts are required. Fortunately, there are considerable economies of scale. Once the system is working well, the storage capacity can easily be expanded and costs per unit will go down. It is an economic law that economies of scale inevitably result in a degree of concentration.

Whereas it might be expected that in the end permanent archiving will be a natural part of the task of every national and depository library or institute, especially for the national publications, already today the international publications might worldwide be taken care of by a limited number of institutions (Safe Places), dedicated to this task. The KB has the ambition to be one of those Safe Places. In the opening address for the EU conference 'Permanent Access to the Records of Science' on 1 November 2004 the Minister of Education, Culture and Science expressed support for this policy line.

In 1993 the KB decided to build a deposit collection of electronic publications, which was considered to be a logical extension of the deposit collection of printed publications already in place. General policy lines were formulated, and in 1995 the KB started actually experimenting on a small scale with facilities for handling electronic publications. In 1996 the KB and the Dutch Publishers Association (NUV) agreed on an arrangement for the voluntary deposit of offline publications. At the same time discussions were initiated with Elsevier Science with the aim of acquiring the content of Elsevier electronic journals. In June 1996 the first experimental bilateral archiving agreement was signed, which allowed the KB to load electronic journals with Dutch imprint in the first experimental deposit system. Soon afterwards a similar archiving experiment was agreed on with Kluwer. A landmark electronic archiving agreement was drawn up with Elsevier Science in August 2002: the experimental agreement of 1996 was expanded to cover the entire set of Elsevier. In total, the agreement gave the KB and its e-Depot the responsibility for preserving approximately 1,500 journals covering all areas of science, technology and medicine. As new journals are published by Elsevier, they too are added to the e-Depot. The agreement also

covers journals digitized as a part of Elsevier's retrospective digitization project. [Click here to see the Base agreement for the archiving of Publisher Content.](#)

After the agreement with Elsevier, the KB concluded similar agreements with Kluwer Academic Publishers (2003), BioMed Central (2003), Blackwell (2004), Oxford University Press (2004), Taylor & Francis (2004), Sage (2005), Springer (2005) and Brill Academic Publishers (2005). As this list of publishers makes clear, the KB does not discriminate between the places of origin, the publisher's business model, marketing strategy or any other features. In June 1999 the Dutch Publishers Association agreed on a new arrangement, which covered offline as well as online electronic publications with Dutch imprint (up-dated again in June 2005). [Click here to see the Dutch Publishers agreement](#)

All KB agreements dictate that the KB will preserve what the publisher sends to the library. According to Oltmans, this means the archived content is "exactly the same as the published content" (personal communication, August 24, 2005). This may need to change as publications become more complex and include multimedia, dynamic content, etc., but for now, the KB's policy is to preserve "as is". As a part of the agreements, the KB provides on site access to the journals on a current basis to all on site, authorized library users. It covers new publications as well as digitized backfiles. In addition, should there be a catastrophic disaster such that the publisher is inoperable for a long period of time, the KB would be part of the interim service system. Finally, should the publisher or a successor cease interest to make these journals available on a commercial basis, as an official archive the KB could open access to all on a remote (in addition to walk-in) basis. In September 2003, the KB signed an archiving agreement with BioMed Central securing free access to over 100 Open Access journals covering all areas of Biology and Medicine.

## **The e-Depot**

The first experimental deposit system was based on AT&T Right Pages (software for storage and retrieval of electronic journals). When in the course of 1996 Right Pages was withdrawn from the market, IBM Digital Library was selected to replace the AT&T software. It took until January 1998 before the system became finally operational. It was recognized that IBM Digital Library was only a temporary solution because it did not have the functionality that was needed for a full-scale deposit system. In September 2000, after a European tender procedure, IBM was selected to develop a new system together with KB staff. In this project the expertise of the KB and the technical knowledge and research forces of IBM were combined. In December 2002 the current e-Depot system was delivered. It is now fully operational and embedded in the KB organization, as a department of the Acquisitions and Processing Division.

## **Content Characteristics**

Content of the e-Depot is predominantly driven by the archiving agreements with publishers. In the Netherlands, deposit is on a voluntary basis. Nevertheless, because of the KB's outstanding relationships with publishers, 95% of all regular publishers deposit their collections with the KB. At present, the e-Depot is receiving two types of electronic publications: offline media (e.g., CD-ROMs that are completely installed before they are loaded into the e-Depot, including operating systems and additionally required software); and online media such as high-volume electronic articles deposited by publishers.

## Technical Architecture and Workflow

The technical architecture of the e-Depot (hardware and software) was created through a partnership between IBM and the KB. The infrastructure of the e-Depot consists of both components that were specifically developed for processing, archiving, and maintaining e-publications, and typical digital library functions. According to the NEDLIB Guidelines, the deposit system should be a separate, dedicated entity within the library's digital infrastructure. For the traditional library processes, such as cataloguing, search and retrieval, and user registration and authentication, the KB uses the provisions already in place, thus avoiding duplicating these functions within the deposit system. This approach allows both the depository system and the traditional library systems to evolve at their own pace (e.g. in terms of new functionality and technical updating). Separate entities for e-archiving and for the traditional library also work to keep matters as simple as possible, both for the library and for the system providers.

The deposit system DIAS (Digital Information Archiving System) is the technical core of the e-Depot. The functions at the left of Figure 1 are for receiving and loading: EPO is the Electronic Post Office; BER is the Batch Error Recovery; NBN is the National Bibliographic Number generator. The functions at the right are for search, retrieval, and delivery: GGC is the Central Cataloguing System of OCLC|PICA; KB-TITEL is the local overall catalogue database at the KB; IAA is the function for Identification, Authentication, and Authorization of end users.

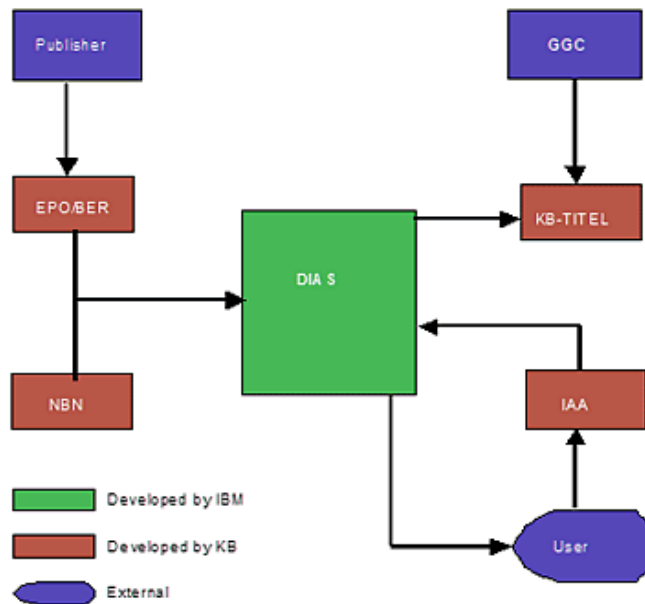

*Figure 1. The Deposit System Within the Digital Library Environment*

The installable cd-based publications are first completely installed on a Reference Workstation including all additionally required software such as image viewers and media players. A snapshot of the installed CD together with the operating system on which is installed is then generated into a disk image. For these electronic publications, it is the disk image which is ingested into the e-Depot. Patron use requires retrieving the disk image and completely installing it onto a workstation.

In contrast to the electronic publications obtained on CD as described above, most electronic publications and their associated files are obtained by the KB via digital tape or are acquired via FTP. Most publications arrive in PDF format. Electronic files are validated via checksums and batched for processing. The processing ingests both the content files (graphics, text, or other material that could comprise an electronic journal article, issue, or volume) and the metadata. It also converts publisher bibliographic data into the KB's standard format and adds a National Bibliographic number which later is used as the unique identifier of the stored item. The publishers provide all necessary descriptive and structure metadata. The functional design of the DIAS is based on the Open Archival Information System Reference Model (OAIS-RM)/ISO 14721:2003. The system is designed to be durable, and provides for scalability, extensibility, and flexibility. It was built using off-the-shelf components as much as possible. The key functions of DIAS are storage and long-term preservation. It allows the manual and automated ingest of digital publications. Once the publication is successfully stored, it is managed for preservation and permanent access, which functionality is currently being developed further.

## Scale

The following chart illustrates the size and growth for the e-Depot, as well as provides a snapshot of 2005 gross content characteristics:

	End 2003	End 2005 (prognosis)
e-journals	1.2 Tb	5.0 Tb
CD-ROMs	0.7 Tb	1.3 Tb
Total storage	1.9 Tb	6.3 Tb
e-journal titles	1,200	3,500
e-journal articles	1,600,000	5,000,000

*Table 1. Terabytes of Storage Used and Quantity of Content by Type in the e-Depot, 2003-2005*

## Users (Designated Community)

The KB's mission statement (<http://www.kb.nl/bst/beleid/missie-en.html>) defines a very broad designated community. It states:

“As a national library the KB provides access to everyone in the Netherlands and beyond. Within this target group the KB directs its attention especially to researchers and other people with a specific interest in Dutch history, language and culture in a wide international context. In addition, the KB wants actively to promote its collections among the general public. This aim to be there for everyone implies an anticipatory attitude and service focused on consumer orientation and reliability.”

In the next four years, the KB mission specifies that it will develop and deploy “a complete package of services that will allow everyone in the Netherlands to have a 'home library'.” Many electronic publications within the e-Depot however, cannot be included in these plans. According to contracts

with publishers (“*Base contract...*” 2004), the KB –and therefore KB users– obtain the following discovery and use rights:

- Information about the publications can be included in the KB’s online public catalog and/or in the National Bibliography.
- On-site usage (designated specifically as “within the premises of the KB’s physical facilities open to the public”) for those persons authorized by the KB
- On-site or remote access by KB staff authorized by the KB to work with the KB Archive; and
- Use as a source for print or fax copies of articles for interlibrary loan within the Netherlands. (In these cases, sending or transferring the electronic file by any means is expressly forbidden.)

Contracts also mandate that the KB provide access at a “minimal level of functionality” which includes:

1. the ability to perform bibliographic searches;
2. a list of publisher publications at the volume and issue level;
3. a list of issue content;
4. the ability to view articles
5. the ability to view the copyright as supplied by publishers; and
6. the ability to download articles or “smaller than article components (e.g., metadata) consistent with the terms of each contract.

These stipulations clearly specify access functionality, but obviously influence the characteristics which must be preserved within the e-Depot system. With the additional stipulation that the e-Depot preserve the files “as is,” the functionality being preserved is similar to that offered through the publisher’s web-based system or to the “look and feel” of the printed version via a PDF document. The KB considers the current system to be preserving “all characteristics.”

Communication with Oltmans further relates that if the characteristics of the publications being preserved change, the KB could be forced to make choices (one specific characteristic over another). In the event that this happens, the KB will likely conduct user studies so that end user opinion would help determine functionality and characteristics to be preserved into the future.

### **KB Audit Dates**

Tentative: between 5-9 December

### **References**

*2004 annual report.* (2005) The Hague: Koninklijke Bibliotheek.

*Koninklijke Bibliotheek Base Contract 092004.* Unpublished template of archiving agreement. (2004) Koninklijke Bibliotheek.

Steenbakkens, J. F. (2004). Treasuring the digital records of science: archiving e-journals at the Koninklijke Bibliotheek. *RLG DigiNews*, 8. Retrieved Jul 19, 2005, from [http://www.rlg.org/en/page.php?Page\\_ID=17068#article0](http://www.rlg.org/en/page.php?Page_ID=17068#article0).

van Wijngaarden, H. and Oltmans, E. (2004). Digital Preservation and Permanent Access: The UVC for Images. In (Eds.), *Final Program and Proceedings of the IS&T 2004 Archiving Conference*. San Antonio, TX. Springfield, VA: Society for Imaging Science & Technology.

## Appendix 1: KB Organizational Chart

