

## THE MANHATTAN PROJECT

The Manhattan Project and the Development of the Atomic Bomb: Some Resources 3

### Smashing the Atom!

#### Science Unlocks Door to New World for Man

By BOB FEARCE

Since the advent of the 19th century man has built a bridge between fantasy, the land of which the world has dreamed, and the world of the day before him. The next step is all the more certain.

Two of the men of the world, and two of the most brilliant scientists of the age, have just taken the first step toward the realization of a dream which has been the goal of man since the dawn of time. They have just taken the first step toward the realization of a dream which has been the goal of man since the dawn of time.

The world will continue to take the steps of this scientific advance, as a great scientific step along the road of progress.

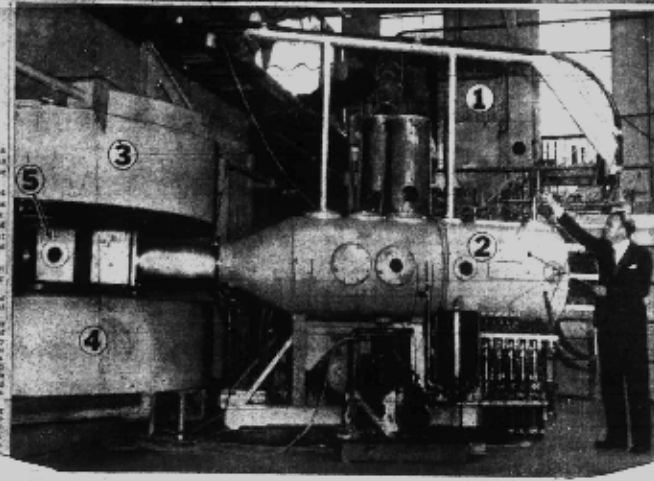

#### PROPHET—

page the article paid for a future building of some kind with an atomic reactor, a machine which would produce energy without smoke. In a process, more than 100,000 tons of uranium and 100,000 tons of plutonium were used in the process.

When man reached the discovery of the great atom, he was not only a great step toward a new world, but also a great step toward a new world.

Guided by the courage and genius of the great men of science, the world has taken a great step toward a new world.



### In This Issue

Recently the successful trial of the Large Hadron Collider brought the awesome power and mystery of the atom once again to the attention of many outside the physics community. The history of atomic science is the subject of this issue of *FOCUS on Global Resources*, in particular the Manhattan Project and development of the first nuclear weapon during World War II.

The topic was chosen by the Center's Liberal Arts Interest Group, a group formed within the CRL membership to identify primary source materials for use in undergraduate teaching and research. The group determined that Manhattan Project resources could contribute to upcoming advanced seminars in history at a number of CRL universities and colleges. CRL digitized key materials for use in those seminars, and this issue points to some of them.

On page 1: *San Francisco Examiner* article on nuclear fission (August 7, 1945). From CRL collections.

*continued from page 1*

As Janet Farrell Brodie of Claremont Graduate University notes in her introduction to the collection, this material contradicts or raises new interpretive possibilities with regard to long-held narratives about the Manhattan Project. We hope that this sampling also serves as an introduction to other CRL holdings on the subject, available through interlibrary loan to researchers at [CRL member institutions](#).

—*Bernard F. Reilly, Jr.*  
*President*

# The Manhattan Project and the Development of the Atomic Bomb: Some Resources

Janet Farrell Brodie  
Professor of History  
Claremont Graduate University



Wartime America learns about atomic weapons (*San Francisco Examiner*, August 7, 1945).  
From CRL collections.

The four digitized sets and guide profiled below provide access to an extraordinary array of hundreds of documents about the Manhattan Project and the broader Manhattan Engineer District during and immediately after World War II. Some reproduce entire books (such as the Smyth Report, early volumes of the official history of the Manhattan Project); some reproduce diagrams, maps, drawings, and photographs; some contain formally typed minutes of meetings or formal memos; some include press releases; and others contain handwritten notes and reports. This is rich, engrossing, important material that provides detailed—and new—insight into the history of America’s multi-faceted programs to produce nuclear bombs and nuclear energy in the war years. Given the attention lavished on the Manhattan Project since its beginning—and in spite of all the biographies, personal memoirs, government reports, and voluminous historical accounts—it remains surprising how much new material continues to be made available as archives are declassified. The group of materials summarized below is one of the most important in recent years to be made available digitally.

## Manhattan Project: Official History and Documents

The “[Guide to Manhattan Project: Official History and Documents](#)” begins with a useful and detailed table of contents for easy identification of pertinent materials about the early phases of the bomb project, including such information as radioisotope production and distribution and information about the Nuclear Powered Aircraft program. The documents cited in the guide are accessible in the “[Manhattan Project: Official History and Documents](#)” set.

## Bush-Conant File

The “[Bush-Conant file relating to the development of the atomic bomb, 1940–1945](#)” gives readers access to important exchanges between two of the major civilian political leaders involved in creating and overseeing the bomb project—Vannevar Bush and James Bryant Conant. Bush was vice president of the Massachusetts Institute of Technology and Conant was president of Harvard when appointed to head new organizations charged with oversight of research and development of a fission bomb project. Bush headed the National Defense Research Council (NDRC), created in June 1940, to coordinate research into fission and fission weapons. In June 1941, the new Office of Scientific Research and Development (OSRD) took control of bomb research. Conant led it with the NDRC subsumed under it. This file begins with a user-friendly typed index to the materials. It should be noted that the file contains materials from

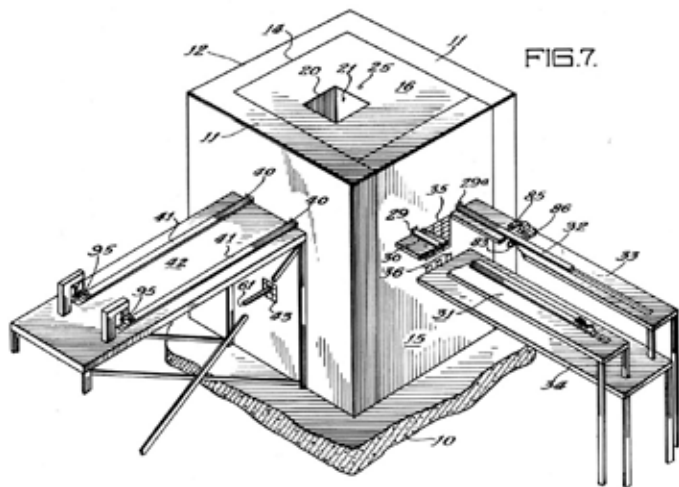

Witnesses:  
Robert S. Siffert  
Francis W. Taylor  
Henry M. Johnson

Inventors:  
Enrico Fermi  
Leo Szilard  
Richard Swendsen  
Attorney

A patent application illustration, filed on December 19, 1944, of the “atomic pile” developed by Enrico Fermi and Leo Szilard. Courtesy of the University of Chicago News Office.

individuals other than Conant and Bush scattered throughout, including such major figures as Ernest O. Lawrence and Leslie Groves, as well as important materials about the Manhattan Project’s relationship with the University of California.

## Harrison-Bundy Files

The third collection, “[Harrison-Bundy files relating to the development of the atomic bomb, 1942–1946](#),” contains correspondence between two key advisors to Secretary of War Henry Stimson: George L. Harrison, president of the New York Life Insurance Company, and attorney Harvey H. Bundy. The two helped Stimson establish the Interim Committee to consider postwar uses of the bomb.

## Top Secret Correspondence

The file titled “[Top Secret](#)” [Correspondence of the Manhattan Engineer District, 1942–1946](#)” contains diverse materials such as telegrams, memos, letters, and telephone call transcripts between top-ranking officials on the bomb project. It includes materials about the Trinity Test, much about preparing for the Hiroshima and Nagasaki bombings,

and subsequent American investigations of the atomic bomb damage in Japan. Materials range from formerly top secret reports about production and transportation of bomb materials to the handwritten scribbles of one of the scientists who observed the Trinity Test in July 1945.

The material in all of the files is of incalculable value to scholars and researchers but it has great potential as well for use in undergraduate courses. Some individual memos or letters contain information that students will find contradicts or sheds new interpretative possibilities on longstanding interpretations of wartime decision-making about how and where to use the bomb as well as other decisions by administration officials and leading MED scientists and academics. Documents provide information about many of the lesser-known political, military, and scientific personnel involved with the bomb project. Students researching the actions or ideas of such individuals will have to sharpen research skills to learn more about these individuals, hone interpretative skills for interpreting documents, and think about placing events in a larger historical context. The materials in the “top secret” correspondence file may prove especially intriguing to students, and significant in the new contexts they illustrate about ways secrecy operated. The files also contain much information about hopes for peacetime uses of nuclear energy that might prove intriguing for students in the history of technology or science studies.

## Preservation Notes

The collection as a whole is unevenly legible and some entire reels contain documents too light to be read. This stems from problems with the original documents but can be disappointing nevertheless. Also, searching through the files can be as exciting and equally as frustrating as going on a treasure hunt because of inadequate finding guides, tables of contents, or indexes. The individual collections do not include explanations of the provenance of the collection or introductory overviews of the contents. These are relatively minor problems in a collection this rich and should not deter anyone looking for serious treasures about America’s nuclear beginnings. ❖

**FOCUS on Global Resources**, published quarterly, is compiled by CRL's Communications Department. Don Dyer, Editor. Special thanks to Virginia Kerr, Yoseline Pluviose-Louisma, Alan Diep, and Darmon Lewis. Graphic design services provided by Molly O'Halloran, Inc.

ISSN #: 0275-4924

### Center for Research Libraries Staff Contacts (800) 621-6044

President  
Bernard F. Reilly x 334  
reilly@crl.edu

Assistant to the President  
Yvonne Jefferson x 319  
jefferso@crl.edu

Vice President/Director of Programs  
and Services  
Melissa Trevvett x 316  
trevvett@crl.edu

User Services Liaison  
Mary Wilke x 351  
wilke@crl.edu

Director of International Resources  
James Simon x 324  
simon@crl.edu

Director of Technical Services  
Amy Wood x 327  
wood@crl.edu

Director of Information Systems  
Patricia Xia x 341  
pxia@crl.edu

Head, Access Services  
Kevin Wilks x 314  
wilks@crl.edu

Head, Stack Management  
Patricia Finney x 328  
finney@crl.edu

Digital Program Manager  
Virginia Kerr x 265  
vkerr@crl.edu

### Global Resources Program Contacts (800) 621-6044

Director  
James Simon x 324  
simon@crl.edu

Project Manager—DSAL Project  
Gerald Hall x 318  
hall@crl.edu

Project Coordinator—Global  
Resources Network  
Judy Eckoff-Alspach x 323  
eckoff@crl.edu

Project Coordinator—ICON  
Carolyn Ciesla x 315  
cciesla@crl.edu

### Contact for Information Regarding: (800) 621-6044

Billing/Invoicing/Deposit Accounts  
Accounting Department x 346

Membership/Communications/  
Public Relations/Marketing  
Don Dyer x 317  
dyer@crl.edu

CRL Publications Orders (*non-FOCUS*)  
Meeting/Schedules  
Yvonne Jefferson X 319

Loans/Photocopies/Demand  
Purchases  
Access Services Department x 314

Microfilm/Microfiche Sales  
Lorraine Farley x 336  
farley@crl.edu

Purchase Proposals  
Mary Wilke x 351

Collection Deposits  
Mary Wilke x 351